



Supplier Transport Label

**PISTON INTERIORS, LLC
NAO SAFETY SYSTEM SUPPLIER
TRANSPORT LABEL**

TEMPLATE SPECIFICATION REVISION 4, MAY 1, 2024

Supplier Transport Label

INTRODUCTION

This standard describes the requirements for two common Piston Interiors Supplier Transport Label (STL) templates used on unit loads. This standard does not supersede or replace any applicable safety or regulatory marking or labeling requirements. This standard is to be applied in addition to any other mandated labeling requirements.

The following have been identified as the label types in use at Piston Interiors, LLC:

- Individual container
- Master Load container (Optional)

Note: Mixed pallets are also allowed and require proper individual container labeling.

In other words, mixed parts will require a master label for each part number on the pallets (resulting in multiple master labels).

Keep like parts together.

It is the responsibility of the supplier to provide bar code marked labels that meet the specifications outlined in this standard. Non-compliance with these requirements will be recorded and an Incident Report will be generated by Piston Interiors. All associated costs for extra handling and relabeling will be supplier's responsibility.

Maximum weight (gross) of a container shall not exceed 40 lbs. (18Kg) for any returnable or non-returnable container.

Maximum weight (gross) of a load unit (pallet) to be handled with a forklift or pallet jack shall not exceed 2400 lbs. (1089Kg).

Container to be handled manually must fit within a standard 45" x 48" pallet.

Containers must be suitable for KANBAN racks. Any specific details regarding packaging refer to standard **PES-004** (Ref. IRV-SQ-ST-009).

In this document, the word "shall" indicate a requirement and the word "should" indicates a recommendation.

All exhibits are for illustrative purposes only and may not be to scale or bar code print quality standards.



Supplier Transport Label

LABEL CONCEPTS

This section defines a standardized label concept for the Piston Interiors Supplier Transport and Master Labels.

LABEL SIZE

The Piston Interiors transport label is designed around the label sizes of the AIAG B-10, B-11 and B-16 with a minimum recommended size of 102 mm x 165 mm (4.0 inches x 6.5 inches).

BUILDING BLOCK

The following illustrations and matrix describe the distribution of data within the label templates:

- The label is divided into horizontal blocks or sub-blocks.
- Each block or sub-block may be left blank or may contain text /128 bar code data.
- Data content shall not exceed the stated block/sub-block limits.
- Building blocks shall be stacked vertically.
- A horizontal line shall separate building blocks.
- Each building block is approximately 18mm (0.87”) in height.

STL SINGLE CONTAINER TEMPLATE

FROM: YOUR COMPANY NAME ADDRESS LINE 1 ADDRESS LINE 2 CONTACT EMAIL MADE IN XXX	TO: PISTON INTERIORS 2A FAWCETT DRIVE DEL RIO, TX 78840 ADDRESS LINE 4 SITE: 100-DELRIO	PO# (K): A2B4C6
 A2B4C6D8E0F2G4H PART# (P):		PART DESC: Outer Retainer Clip Outer Retainer Clip
 A2B4C6D8E0F2G4H6I8J0K2L4M LOT# (1T):		ENG. DATE 20APR 2021
 A2B4C6D8E SERIAL# (S):		QUANTITY (Q): 123456.123
SUPPLIER FREE AREA		



Supplier Transport Label

MASTER STL CONTAINER TEMPLATE

MASTER LABEL		
FROM: YOUR COMPANY NAME ADDRESS LINE 1 ADDRESS LINE 2 CONTACT EMAIL MADE IN XXX	TO: PISTON INTERIORS 2A FAWCETT DRIVE DEL RIO, TX 78840 ADDRESS LINE 4 SITE: 100-DELRIO	PO# (K): A2B4C6
 A2B4C6D8E0F2G4H PART# (P):		PART DESC: Outer Retainer Clip Outer Retainer Clip
 123 # PACKS (7Q):	ENG. DATE 21APR 2021	SUPPLIER FREE AREA
 A2B4C6D8E MASTER SERIAL# (M):		QUANTITY (Q): 123456.123

DATA TITLE	DI	DESCRIPTION	B/C	# CHAR W/O DI	TYPE	FONT SIZE
FROM		Ship From: Max 5 Lines of Data, Company Name, Address, Contact Phone/email, *Country of Origin i.e. MADE IN / ASSEMBLED IN (See explanation below)	N	5L	A/N	10
TO		Ship To: Max 5 Lines of Data, Company Name (one line), Address (three lines)	N	5L	A/N	10
SITE	21L	Ship-To ID Code assigned by Piston Interiors	N	10 CH	A/N	18-20
PO #	K	Six Digit Shipping Control Number assigned by Customer	1D	5/6 CH	A/N	12-18
QUANTITY	Q	Quantity, Unit of Measure assumed to be "each" unless mutually defined by Piston Interiors and Supplier. Ref. Customer order. Base 6 digits, decimal, 3 suffix digits for a max of 10.	1D	10 CH	N	18-20
PART DESC		Description of part (two lines)	N	30 CH	A/N	12-18
PART #	P	Item Identification code assigned by customer	1D	15 CH	A/N	18-20
LOT #	1T	Trace ability Number assigned by Piston Interiors/Supplier to identify/trace a unique group of entities (lot, heat, batch)	1D	25 CH	A/N	18-20
# PACKS	7Q	Number of Individual Packs in a Master Pack followed by the two-character Unit of Measure code	1D	3 CH	N	18-20
ENG. DATE		Date Structure Mutually Defined DDMMCCYY as Engineering / Manufacturing Date	N	9 CH	A/N	12-18
Container Serial:	S	Serial Number used for uniquely identifying an individual transport unit not to be repeated for 365 days.	1D	9 CH	A/N	18-20



Supplier Transport Label

Master Serial:	M	Master Serial Number is used for Master packaging containing like items on a single order. Supplier Code assigned by customer combined with supplier generated ship pack serial number.	1D	9 CH	A/N	18-20
SUPPLIER AREA		Shall adhere to all guidelines set forth in AIAG B-10/16 standard, e.g. (1P) Supplier Part Number. For suppliers requiring additional space.				
<p>Note: Font Size shall be as large as practical for information printed. Data Titles are all uppercase and the same size (6-9pt). Font shall support slash zero and should be sans serif (without tails, e.g. Helvetia). Symbology: 1D=Code 128, should have an 'x' dimension of 0.015". N=No Bar Code.</p>						

FONTS

All fonts on the STL shall be bold UPPER CASE for readability. Font Size shall be as large as practical for information printed. Font should support slash zero and shall be sans serif (without tails, e.g. Arial, Helvetia or equivalent). Color fonts and Italics shall not be used. Font size selection shall accommodate the data to be printed. The same font size may vary between printers due to several factors, including printer resolution.

MADE IN / ASSEMBLED IN XXX

Products claiming to have been “MADE IN / ASSEMBLED IN (Country Name)” must have been “all or virtually all” made in the Country named in the label. This means all significant parts, processing, and labor to produce the item must have originated in the country specified.

LINEAR BAR CODE

The linear symbology used in this standard shall be Code 128, allowing for a quiet zone at each end of the symbol, of at least 6.4 mm (0.25 inches).

- The four characters %, /, \$, +, shall not be used.
- The minimum height of the symbol shall be 10.2 mm (0.4 inch).
- Part numbers with leading zeros and spaces shall not be omitted.
- “X” Dimension. The dimension of the narrowest element (X dimension) range shall be from 0.33 to 0.43 mm (0.013 to 0.017 inch) as determined by the printing device. Symbols with narrow elements at the lower end of this range may require special care to meet the print quality requirements.
- Each linear bar code shall have the appropriate data identifier included within the bar code data but not in the human readable. Example if you are shipping a quantity of 120 pieces the bar code would read Q120 when scanned but will should only 120 as the human readable above the bar code.

PRINT QUALITY

ISO/IEC 15438 and ISO/IEC 15415 Bar Code print quality test specification for Linear Symbols shall be used to determine the print quality. The minimum symbol grade should be 1.5/10/660, where:

- Minimum Print Quality grade = 1.5 (C) at the customer’s point of scan
- Recommended Print Quality grade \geq 2.5 (B) at the point of printing the symbol
- Measurement Aperture = 0.254 mm (0.010 inch)
- Light Source Wavelength = 660 nanometers (nm) \pm 10 nm.

Supplier Transport Label

It is important that the linear bar code symbol be decodable throughout the system of use. The symbol quality and measurement parameters should ensure scan-ability over a broad range of scanning environments. Print quality at the point of production should be higher (Print Quality Grade \geq B) than the requirements at the point of use. Unattended scanning may require a higher print quality grade than that identified above. Consequently, those implementing this standard for unattended applications should discuss print quality requirements with the labeler. To reduce errors associated with the mislabeling of containers, on-demand printing should be placed as close as possible to the point of application. Studies have shown that batch, central printing, and pre-printed labels have higher error rates associated with mislabeling (wrong label on the container). Direct thermal and thermal transfer printer devices produce the most consistent results for symbol print quality and text uniformity. The safety system supplier should have an in-house verification process for ongoing quality control of all labels.

BEST PRACTICES THAT MUST BE FOLLOWED

Bar codes with a high bar gain/loss dramatically decrease scanner performance and decode-ability without affecting ANSI print quality.

- Width of the narrow bars shall be the same width as the narrow spaces, ideally within +/- 10%, but shall be within +/- 25%.

Bar Gain/Loss can be caused by many factors in the printing process such as the ink applied to form the bars spreading on the background material. The ideal situation would be to have 0% variation. In case of high bar gain/loss, adjustments need to be made to the original artwork, plate marking, ink application, ribbon formulation, and print head temperature. Bar code verification equipment should be utilized to bring this deviation as close to zero as possible.

Note: Quality of media (i.e. labels and ribbon) can have a profound effect on image quality and subsequently a scanner's ability to decode a bar code symbol. Safety system suppliers should utilize good quality print materials when making their STL labels.

Supplier Transport Label

LABEL MATERIALS AND PLACEMENT

The STL shall be white with black print (Color should not be used as it may affect the scan-ability of the bar code symbol). The labels should be attached on adjacent sides in accordance with the following illustrations.

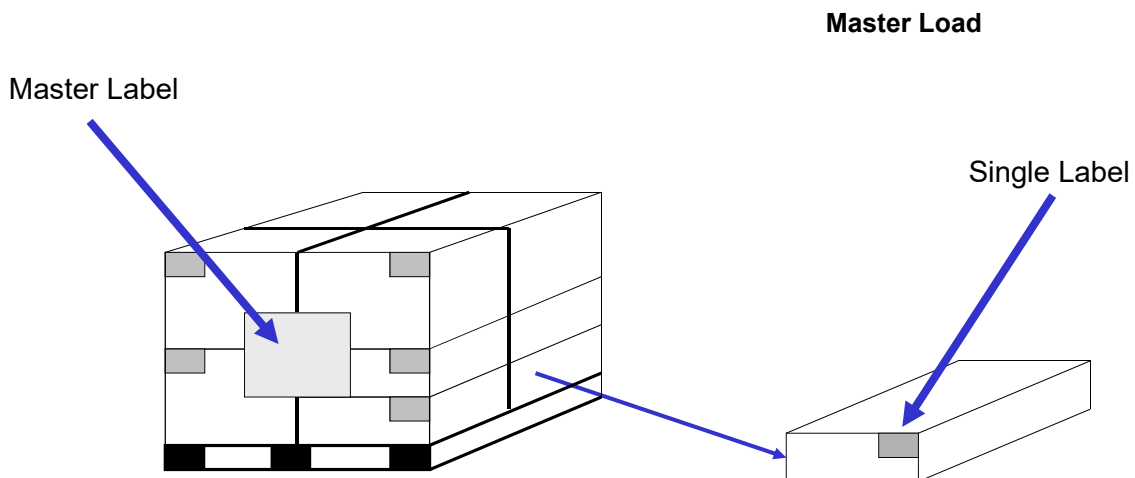
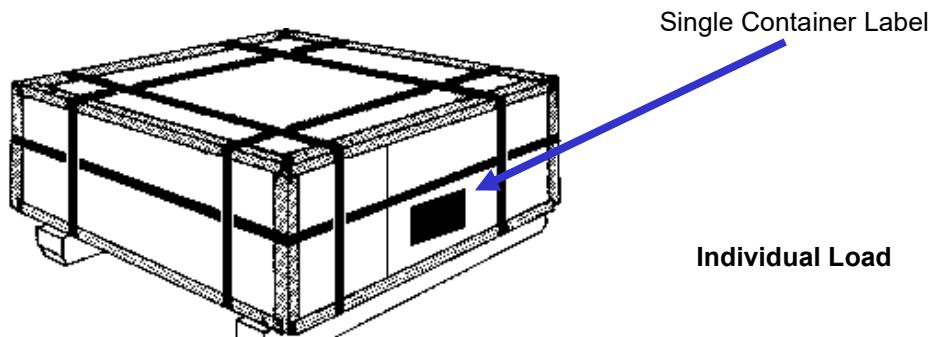



Supplier Transport Label

PISTON INTERIORS PRODUCTS, LLC Supplier Transport Label Certification

SAFETY SYSTEM SUPPLIER BULLETIN

To: PISTON INTERIORS, LLC system suppliers

Piston Interiors is aggressively monitoring compliance with the standard. Piston Interiors plants are authorized to issue IRs (Incident Reports) when a product non-conformance is detected. As part of the Piston Interiors label initiative, safety system suppliers who receive an IR will require re-certification to ensure compliancy. Shipping labels must have all the required data elements, use specified fonts, and include bar codes that can be scanned successfully at all points in the supply chain as outlined in the NAO Safety System Supplier Transport Label specification (this document).

Suppliers may be required to re-submit labels on an annual basis to ensure continued compliancy through accurate and scan-able shipping labels. This will allow Piston Interiors to monitor system success, as well as introduce necessary and ongoing changes to the system. Through this process Piston Interiors will be able to streamline efficiency and increase accuracy with minor number of resources to monitor and maintain label quality.

Special Note: The certification process requires a production shipping label sample with actual shipping data from the supplier company. Therefore, particular attention shall be paid to Part Number and Plant Code information. Part numbers are to be current and relevant with the proper base and suffix information.

Contact Piston Interiors Products for label submission at: <http://Piston Interiors.com>

Supplier Transport Label

TERMS AND DEFINITIONS

TERM	DEFINITION
1D Symbol	1D one-dimensional or linear symbol, such as Code 128. An array (linear sequence) of variable width rectangular bars and/or spaces, arranged in a predetermined pattern, following specific rules, to represent elements of data; these bar and space patterns are referred to as characters . A bar code symbol typically contains a leading quiet zone, a start character, data character(s) including a check character (if any), a stop character and a trailing quiet zone.
AIAG	Automotive Industry Action Group
Alphanumeric	A character set that contains alphabetic characters (letters), numeric digits (numbers), and usually other characters such as punctuation marks.
Bar Code Symbol	The combination of symbol characters and features required by a particular symbology, including quiet zones, start and stop characters, data characters, check characters and other auxiliary patterns, which together form a complete scan able entity.
CAR	Corrective Action Request issued when a product non-conformance is detected.
Character (CH)	The smallest group of elements that represents one number, letter, punctuation mark or other information.
Code 128	For the purposes of this standard, Code 128 shall mean the symbology as described in ISO/IEC15417
Container	A receptacle or flexible covering for shipping goods. Example is a box, bag, package or pallet. (See also Transport Unit and Pack, Package or Load.)
Customer	In a transaction, the party that receives, buys, or consumes an item or service. e.g. PISTON INTERIORS PRODUCTS, LLC.
Customer Part Number	The part number as defined by the customer.
Data Element	The smallest named item of information that can convey data, analogous to a field in a data record or a word in a sentence.

Supplier Transport Label

Data Element Separator	The special character used to separate data elements in a data format.
Data Identifier (DI)	<p>A specified character (or string of characters) that defines the general category or intended use of the data that follows. Data Identifiers are defined by ANSI MH10.8.2 / ISO 15418.</p> <p>The DI is not part of the data.</p>
ECC (Error Correcting Code)	A technique used at the byte level to detect and correct data transmission errors. Supplemental bits introduced or source encoded into a data stream to allow automatic correction of erroneous bits and/or derivation of missing bits, in accordance with a specific computational algorithm. See also “Error Correction Level.”
Element	A single bar or space in a linear or stacked symbol or a single cell (module) in a matrix symbol (not the same as Data Element).
Element Width	The thickness of an element measured from the leading edge of an element to the trailing edge of the same element (see X dimension .)
Human Readable Interpretation	The human readable letters, digits or other characters representing the data encoded in/and printed along with the linear bar code.
Item	A single part or material purchased, manufactured and/or distributed.
IPP	Initial Production Part
Label	A piece of paper, plastic, card stock or metal that is marked (by printing or some other means) and attached to an object to convey information. For purposes of this document, attachment of a label is to be on the exterior of a container.
Lot	A quantity of homogeneous material either manufactured or received.
Manufacturer	Actual producer or fabricator of an item; not necessarily the supplier in a transaction.
Master Load	A multiple pack or unit load of common items (sharing a single part number), such as a pallet.
Message	A continuous stream of data elements, including formatting characters and delimiters, to be encoded in a (two-dimensional) symbol or set of symbols.

Supplier Transport Label

Message Envelope	A pair of elements consisting of a Message Header and a Message Trailer that delimits the start and end of a data stream in a given message.
Message Header	A character or group of characters that defines the start of a Message Envelope.
Message Trailer	A group of character used to identify the end of a Message Envelope.
Pack, Package or Load	A transport package (container) that provides protection and containment of items plus ease of handling by manual or mechanical means, for example: bags, cartons, pallets, bins and racks.
Pallet	A platform to hold unit loads, permitting stacking of materials and transport packages, and the movement of the materials as a single load. A pallet may be either expendable (e.g. wood) or returnable (e.g. plastic).
Part	An identifiable item that has a unique name and/or number assigned to it.
Part Number	A unique code that identifies a part, assembly, component or kit.
Quantity	On a label, the marking that indicates the number of parts or items or the amount in any other unit of measure that is contained within the package.
Quiet Zone	Areas free from interfering markings surrounding a bar code symbol and, in particular, preceding the start character and following the stop character. Also referred to as “light margin” or “clear area”.
Reader	A device consisting of a scanner and a decoder.
Scanner	An electronic device to collect and convert reflected light from the elements (e.g., bars and spaces in linear symbols) of a symbol into electrical signals for processing by the decoder.
Serial Number	A string of numeric or alphanumeric characters in the issuer’s information system used for uniquely identifying an individual item or entity for its life.
Shall/Should	In this document, the word “shall” indicate a requirement and the word “should” indicates a recommendation.
Ship From	On a transport label, the address of the location where the carrier will return the shipment if the container is undeliverable.
Ship To	On a transport label, the address of the location where a carrier will deliver the shipment.

Supplier Transport Label

SQA	Supplier Quality Assurance is a department located at each assemble facility.
SSD	Supplier Support Development is a subgroup located at PISTON INTERIORS PRODUCTS, LLC corporate facilities.
Structure	The order of data elements in a message.
Supplier	In a transaction, the party that produces provides or furnishes an item or service.
Symbol	A graphic array of light and dark elements that forms a complete scan able entity.
Symbology	A standard means of representing data in bar code form. Each symbology specification sets out its particular rules of composition or symbol architecture.
Syntax	The way in which data are combined to form messages. Syntax also includes rules governing the use of appropriate identifiers, delimiters, separator character(s) and other non-data characters within the message. Syntax is the equivalent of grammar in spoken language.
Transport Unit	One or more transport packages or other items held together by means such as strapping, interlocking, glue, shrink wrap, or net wrap, making them suitable for transport, stacking, and storage as a unit.
Unit Load	One or more transport containers or other items held together by means such as strapping, interlocking, glue, shrink wrap or net wrap, making them suitable for transport, stacking and storage as a unit.
X Dimension	The intended width of the narrowest elements (for bar codes or two-dimensional symbols) required by the application, symbology specification, or both.
Y Dimension	The intended height of the elements dictated by the application, symbology specification, or both.

Supplier Transport Label

Lines-Per-Block (LPB) Calculations

Lines Per Block	Character Height (Points)	Character Height (Millimeters)	Character Height (Inches)
2 LPB	36 pts	12.7 mm	0.50 in
3 LPB	24 pts	8.46 mm	0.33 in
4 LPB	18 pts	6.34 mm	0.25 in
5 LPB	14 pts	4.94 mm	0.20 in
6 LPB	12 pts	4.23 mm	0.17 in
7 LPB	10 pts	3.52 mm	0.14 in
8 LPB	8 pts	2.82 mm	0.11 in
10 LPB	7 pts	2.47 mm	0.10 in

This table is provided as a reference only. Font sizes may vary depending on the software and printer used.

OBTAINING NORMATIVE REFERENCES

Normative references are cited at the appropriate places in the text and the publications are listed hereafter.

AIAG B-10 Trading Partner Label Implementation Standard (B-10 02.00 03/00)

AIAG B-14 Standard for Use of Two-Dimensional Symbols with AIAG Trading Partner Labels (B-14 01.00 12/97)

AIAG B-16 / Global Transport Label Standard (B-16 02.00 11/02)

ISO/IEC 15438 and ISO/IEC 15415 Bar Code print quality test specification.

This document takes into account existing templates from Odette’s Transport Label (OTL) and the GM 1724 ABC as well as design input from JAMA/JAPIA and is based on the AIAG B-10 Standard.

Contact the organizations listed below for information on the references listed in this document:

Email: support@pistoninteriors.com Web: www.pistoninteriors.com